

T2600 Dual Current Relay

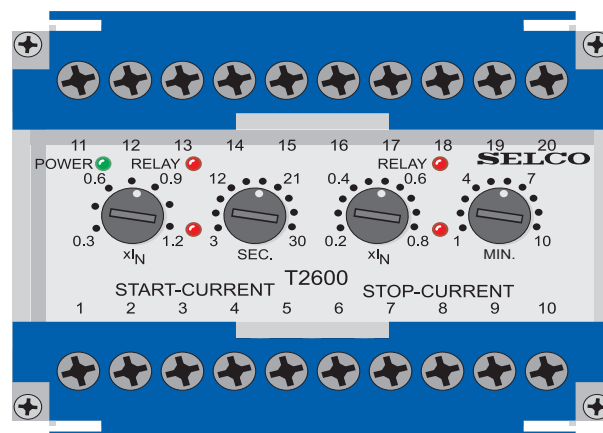

Load depending start and stop signal

- Price competitive due to the combined functions
- Possibility of more than three generators with Extension Unit T2600-50
- Visual indication of power, pick-up and relay tripping on both relays
- High precision digital countdown timer for delayed output
- Accepts high supply voltage variations: 60 - 110%
- Cost effective and highly reliable compact design
- 50 hours burn-in before final test
- Certified by major marine classification societies
- Flame retardant enclosure



Application

The T2600 Dual Current Relay comprises two current relays. The function of the unit is to start or stop the standby diesel generator according to the load situation.

Starting signal to the standby diesel generator is given by output relay terminals 10-9 NC, terminals 8-7 NO and stopping signal is given by output relay terminals 5-6 and 4.

The start relay is normally activated and therefore terminals 10-9 are normally open.

Current is measured in one phase of all 3 generators (more than 3 generators with the T2600-50 Extension Unit) by the current relays through the input current transformers.

Independent of phase angle, both relays will respond to the highest of the currents and any lower current will be completely neglected.

Function

Starting signal

The starting output relay is controlled by the high level start current relay (0.3-1.2 x I_N) with a time delay of 3-30 sec. If one of the 3 input currents (more than 3 inputs with the T2600-50 Extension Unit)

exceeds the current setting for a longer period than the time setting, the output relay will become deactivated.

Stopping signal

The low level current relay (0.2-0.8 x I_N) controls a time delay (1-10 minutes) which again controls the stop output relay.

If all input currents are lower than the current setting for a longer period than the time delay setting of 1-10 minutes, the output relay will be activated.

Short current peak loads will not reset the time delay of 1-10 minutes, but current higher than the current setting for a period of more than 10 seconds will reset the time delay (see diagram on the next page).

An internal time function of 30 seconds (or 1 second, see Type Selection Table) maintains the stop signal until the diesel generator has stopped completely.

As the stop signal from the stop relay is a permanent signal of 30 seconds (or 1 second), changing of standby generator by means of an external selector may result in a transfer of the stop signal. Therefore, the stop functions of all generators should be wired without latching.

Installation

The supply voltage is connected to terminals 1 and 3 or 2 and 3 to suit supply voltage. The relay is connected to the measuring current coming from the CT secondary via terminals 11-12, 13-14 and 15-16. See connection diagram.

The current setting can be calculated according to the following example:

Settings:

All relay scales refer to the primary rating of the main current transformer.

Example:

Generator Rating: 795A

Current Transformer: 1000/5A

Required starting level:

$$90\% \text{ of } I_G = \frac{90 \times 795}{1000} = 715A$$

$$\text{Relay setting: } \frac{715}{1000} = 0.715$$

Required stopping level:

$$40\% \text{ of } I_G = \frac{40 \times 795}{1000} = 318A$$

$$\text{Relay setting: } \frac{318}{1000} = 0.318$$

It is important that standby stopping level setting is below 50% of starting level setting.

Specifications

T2600 Dual Current Relay

Start level	30 - 120%	
Delay	3 - 30 sec.	
Stop level	20 - 80%	
Delay	1 - 10 min.	
Max. voltage	660V	
Voltage range	60 - 110%	
Consumption	5VA at U_N	
Frequency range	40 - 65Hz	
Contact ratings	AC 400V, 8A, 2000VA	DC: 35V, 8A, 150W
Overall accuracy	±3% of highest value	
Repeatability	±1%	
Operating temperature	-20°C to +70°C	
EMC	According to IEC/EN 61000-6-1/2/3/4	
Approvals	Certified by major marine classification societies	
Burn-in	50 hours before final test	
Weight	0.5kg	
Dimensions	70 x 100 x 115mm (H x W x D)	
Installation	35mm DIN rail or 4mm (3/16") screws	

Approvals & Certificates

The T2600 has been approved by major marine classification societies.

For more information about the individual certificates, please visit selco.com

The specifications are subject to change without notice.

Type Selection Table

Standard types: $I_N = 5A$

Type	Terminal		Function
	1-3	2-3	
T2600.0010	230V		30 sec. or 1 sec.*)
T2600.0020	450V	400V	30 sec. or 1 sec.*)
T2600.0030	480V	415V	30 sec. or 1 sec.*)
T2600.0040	450V	400V	30 sec.*), bridge 17-18 = stop current increased 34%
T2600.0050	230V		30 sec.*), bridge 17-18 = stop current increased 34%
T2600.0060	110V	100V	30 sec. or 1 sec.*)
T2600.0070	110V	100V	30 sec. or 1 sec.*), start current delay 1.0-10 secs
T2600.0080	230V		30 sec. or 1 sec.*), normally de-energized start relay
T2600.0090			Extension Unit

*) Pulse duration time for stop signal, bridge 17-18 = 1sec.

